

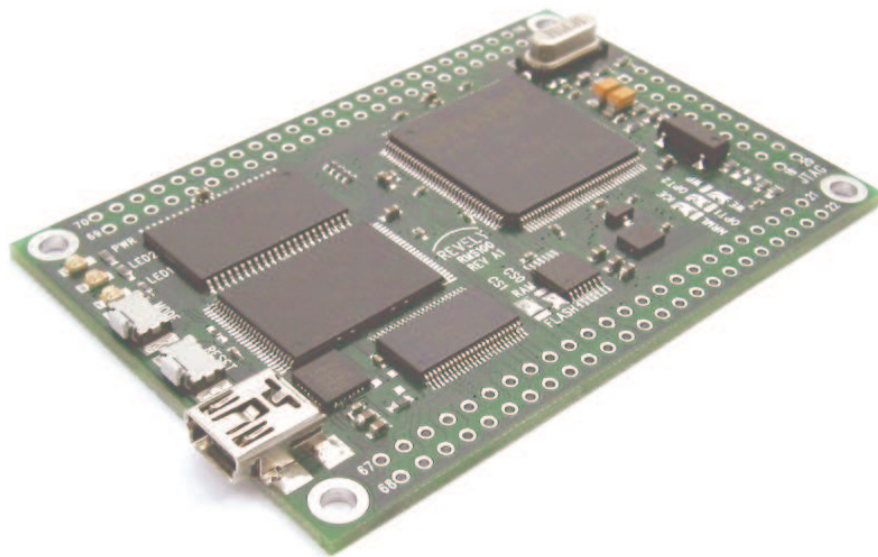

## **RMS100 Technical Manual**



RMS100-1

RMS100-4

RMS100-1-USB

RMS100-4-USB

---

## **RMS100 Technical Manual**

© 2004 Revely Microsystems

Revision 1.0

---

### **Important Information**

The RMS100 is sensitive to ESD (Electro-Static Discharge).  
Handle only at an ESD safe workstation.

The RMS100 is not intended for use in critical equipment intended  
to sustain or protect life or prevent injury.

All software is provided on an as-is basis.

### **Revely Software License**

This software and the software resident on the RMS100 is provided on an as-is basis. Revely Microsystems makes no representation or warranty with respect to the performance or suitability of this software. Revely Microsystems disclaims responsibility for damages, special or consequential connected with the use of this software.

Where Revely source code is made available, the software may be used and/or modified provided the software is run only on a hardware platform supplied by Revely Microsystems. Use of Revely Source code should be visibly acknowledged.



## Table of Contents

INTRODUCTION.....	4
SUPPORT .....	4
BOARD DRAWING .....	4
PIN DESCRIPTIONS .....	5
MECHANICAL DIMENSIONS .....	6
SPECIFICATION SUMMARY .....	7
DEBUG / JTAG CONNECTOR.....	8

## Introduction

Thanks for purchasing the Revely RMS101 SBC.

Revely's RMS100 Development board is the fastest way to start developing with Sharp's LH75401 ARM processor family.

The RMS100 is available with a USB interface for high-speed data transfer at up to 921.6kbps. The USB cable also provides power to the board during development.

Over 100 I/O points on a 0.1" pitch simplify interfacing to the RMS100. All LH75401 general-purpose I/O signals are available in addition to an 8-bit buffered data bus. The interface areas are non-populated, allowing the user to install connectors of their preferred style and mounting orientation.

The RMS100-USB ships with a pre-programmed Bootloader. All parts have an integrated Parallel port to JTAG interface for source level debugging with CrossWorks from Rowley Associates or similar IDE.

## Support

Technical support for RMS100 hardware is available via email. Send a description of the problem to [tech@revely.com](mailto:tech@revely.com) and we'll get a prompt response to your query.

For development tool issues contact tech support those suppliers directly.

## Board Drawing

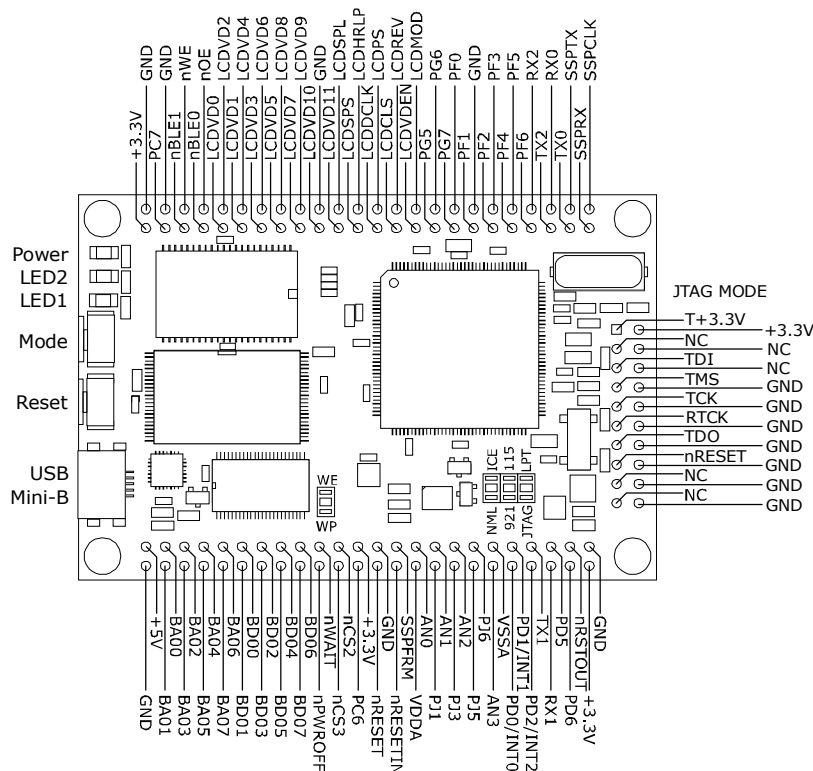

## Pin Descriptions

Pin No.	Description	LH75401 Pin
1	Test +3.3V	
2	+3.3V	
3	NC	
4	NC	
5	TDI	68
6	NC	
7	TMS	65
8	GND	
9	TCK	67
10	GND	
11	RTCK	66
12	GND	
13	TDO	69
14	GND	
15	nReset	62
16	GND	
17	NC	
18	GND	
19	NC	
20	GND	
21	GND	
22	+3.3V	
23	nRSTOUT	72
24	PD6*	71
25	PD5*	73
26	RX1*	74
27	TX1*	76
28	PD2/INT2	77
29	PD1/INT1	78
30	PD0/INT0	79
31	VSSA ADC	88
32	AN3	89
33	PJ6	90
34	PJ5	91
35	AN2	92
36	PJ3	93
37	AN1	94
38	PJ1	95
39	AN0	96
40	VDDA ADC	97
41	SSPFRM	99
42	NC	
43	GND	
44	nRESETIN	62
45	+3.3V	
46	PC6*	33
47	nCS2	29
48	nCS3	28
49	nWAIT	24
50	nPWROFF	

Pin No.	Description	LH75401 Pin
51	BD06	13
52	BD07	12
53	BD04	16
54	BD05	15
55	BD02	19
56	BD03	18
57	BD00	21
58	BD01	20
59	BA06	53
60	BA07	52
61	BA04	56
62	BA05	55
63	BA02	58
64	BA03	57
65	BA00	61
66	BA01	60
67	+5V	
68	GND	
69	+3.3V	
70	GND	
71	PC7*	32
72	GND	
73	nBLE1	25
74	nWE	22
75	nBLE0	27
76	nOE	23
77	LCDVD0	144
78	LCDVD2	142
79	LCDVD1	143
80	LCDVD4	139
81	LCDVD3	141
82	LCDVD6	137
83	LCDVD5	138
84	LCDVD8	135
85	LCDVD7	136
86	LCDVD9	133
87	LCDVD10	132
88	GND	
89	LCDVD11	131
90	LCDSPL	130
91	LCDSPS	129
92	LCDHRLP	128
93	LCDDCLK	125
94	LCDPS	124
95	LCDCLS	123
96	LCDREV	122
97	LCDVDEN	121
98	LCDMOD	120
99	PG5	118
100	PG6	117

Pin No.	Description	LH75401 Pin
101	PG7	116
102	PF0	115
103	PF1	114
104	GND	
105	PF2	113
106	PF3	111
107	PF4	110
108	PF5	109

Pin No.	Description	LH75401 Pin
109	PF6	108
110	RX2	110
111	TX2	105
112	RX0	104
113	TX0	103
114	SSPTX	102
115	SSPRX	101
116	SSPCLK	100

\* These signals typically used by on-board device and functions. Refer to schematics for configuration before connecting external hardware

Power-down signal (Pin 50) controls the +3.3V regulator. Pull low to turn off the regulator and power to all devices. Shutdown current is typically 500uA (less for non-USB models)

## Mechanical Dimensions

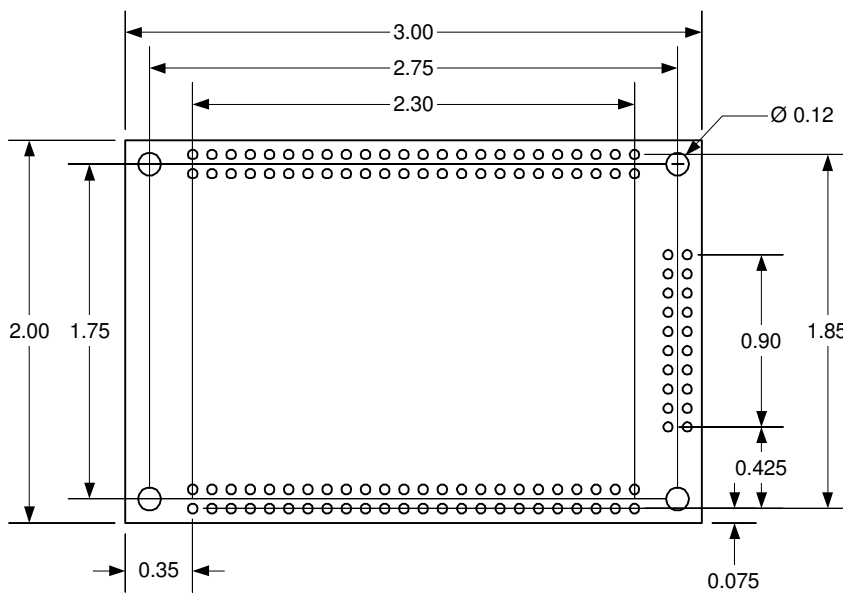

Figure 1 - Plan view of RMS100 (Dimensions in Inches)

## Specification Summary

- Sharp LH75401 Processor
  - 51.6Mhz CPU and Bus Clock
  - 32kHz RTC
- 128KB or 512KB Fast SRAM
  - 15ns for Minimum wait states
- 4 MB Flash Memory
  - 2MB x 16bits
  - 65/25ns Access Time
- Expansion and Interface
  - 8-bit Buffered data/address bus
  - 70 other I/O and CPU signals
- USB 2.0 controller interface
  - Connected to Uart1
  - Transfer at up to 921.6Kbps
- 3 Debug Options
  - Integrated Parallel-Port Debug Interface
  - Pre-programmed loader (-USB version)
  - 20 Pin JTAG to any ARM7 debugger
- Other
  - PCB Size 3.00" x 2.00" x 0.225"
  - Power Supply 5Vdc +/- 10% at 200mA (100mA typical)

## Debug / JTAG Connector

The RMS100 has an on-board interface for direct connection and debugging via a std PC parallel port.

Two modes can be selected:

- 1) Parallel Port Debug Mode – Emulates the Macraigor Wiggler hardware
- 2) Pass-through mode – All JTAG signals are buffered and available for an external debugger.

Both modes use the same 20 pin 0.1" header.

In Pass-through mode, the CPLD routes all JTAG signals according to the 20-pin ARM standard.

In Parallel Port mode use Revely's DBG-4FT cable for direct parallel port connection.

JTAG Pin	Parallel Port Pin	JTAG Pin	Parallel Port Pin
1	2	11	7
2	15	12	20
3	3	13	8
4	16	14	21
5	4	15	9
6	17	16	22
7	5	17	10
8	18	18	23
9	6	19	11
10	19	20	24